

Irrigation/reticulation system specifications



Adopted: June 2007

Contents

Irrigation / Reticulation System	1
Specifications	1
Foreword	5
1. Water Supply	5
1.1. Water Source(s)	5
1.2. Water Allocations and Licensing	6
1.3. Flow monitoring	6
2. Bore Construction	6
2.1. Diameter and Depth	6
2.2. Verticality and alignment	6
2.3. Drilling Method	6
2.4. Gravel Packing	6
2.5. Casing	6
2.6. Screen	6
2.7. Test Pumping	6
2.8. Yield	7
2.9. Water Analysis	7
2.10. Casing Termination	8
3. Pumping System	8
3.1. Pump	8
3.1.1. Discharge Column	8
3.1.2. Drop Cable	8
3.2. Headworks	8
3.2.1. Components	8
3.2.2. Bore Headworks Junction Boxes	8
3.2.3. Pressure Take Offs	9
3.3. Filtration	9
3.3.1. Irrigation Tanks	9
3.3.2. Pumping Stations	9
4. Electrical Works	9
4.1. Power supply	9

4.2. Electrical Cabinet/Cubicle	9
4.2.1. Location	10
4.2.2. Cubicle Construction	10
4.2.3. Base	10
4.2.4. Aerial Pole.....	10
4.3. Electrical Components	10
4.3.1. Switch Board	10
4.3.2. Control Panel	11
4.3.3. Motor Starting Equipment.....	11
4.3.4. Fault Current Limiters.....	11
4.3.5. Circuit Breakers	11
4.3.6. Residual Current Devices	12
4.3.7. Switches and Isolators.....	12
4.3.8. Voltage Transformer	12
4.3.9. Pump Circuit Breaker.....	12
4.3.10. Controller	12
4.3.11. Fans/Heaters	12
4.3.12. Surge Suppression	12
4.3.13. Interference.....	12
4.3.14. Earthing	12
4.3.15. Cable Pits.....	13
4.3.16. Labelling	13
4.3.17. As Constructed Drawings	13
4.3.18. Operation	13
5. Irrigation System	14
5.1. Design	14
5.1.1. Efficiency	14
5.1.2. Stations.....	14
5.1.3. Format.....	14
5.2. Conduits.....	14
5.3. Mainlines	15
5.3.1. Mainline Pipes.....	15

5.3.2.	Mainline Fittings	15
5.3.3.	Mainline Isolation Valves	15
5.3.4.	Air Release Valves	15
5.3.5.	Thrust Blocks.....	16
5.3.6.	Installation requirements.....	16
5.4.	Cabling	16
5.4.1.	Conventional Type Cabling.....	16
5.4.2.	Size and Type for Conventional Cabling.....	16
5.4.3.	Connection for Conventional Cable.....	17
5.4.4.	Junction Boxes.....	17
5.5.	Solenoid Valve Assembly.....	17
5.6.	Valve Boxes.....	17
5.7.	Lateral Lines.....	17
5.7.1.	Pipes.....	17
5.7.2.	Fittings.....	18
5.7.3.	Installation Requirements.....	18
5.8.	Sprinklers.....	18
5.8.1.	Size and Type.....	18
5.8.2.	Risers.....	19
5.8.3.	Height and Adjustment.....	19
6.	Irrigation Control System	19
6.1.	Controller	19
6.2.	Infield Communication / Design and Configuration	19
6.3.	Sensors	20
6.4.	Flow Meters.....	20
6.5.	Lightning/Surge Protection	20
6.6.	Central Irrigation Control System Connection	21
6.7.	Two Wire Irrigation Systems Requirements.....	21
7.	Commissioning.....	21
7.1.	As Constructed Plans.....	21
7.2.	Training	22
8.	Handover Procedure to City of Swan	22

8.1. Testing Requirements	22
8.2. Water Allocation	22
8.3. Transfer of Water Entitlements.....	22
8.4. Certificate of Compliance Rainman System Installation	22
8.5. Bore Construction Details.....	22
8.6. Bore Service and Logs	22
8.7. Irrigation Pump Service.....	23
8.8. Constructed Drawings.....	23
9. Drawings/Attachments.....	24
9.1. Bore Head / Discharge / and Flow Meter Assembly	24
9.2. Bore Head- Junction Box	25
9.3. Electrical Cubicle	26
9.4. Air Release, Mainline Isolation, Flushing Valve, Solenoid Valve Assembly & Sprinkler Installation	
28	
9.5. Central Hub Design and Configuration	29
9.6. Lightning/Surge Protection	30
9.7. TWIN Field Cable Sizing	31

Foreword

The City of Swan is committed to the sustainable use of water resources and maximizing efficiency of its landscape irrigation systems.

The purpose of this standard specification is to provide a concise point of reference for the design and installation of landscape irrigation systems and shall be referred to in the assessment for approval of development of public open spaces. All irrigation designs will need to take into consideration future ground water allocation reductions.

1. Water Supply

1.1. Water Source(s)

A suitable water source shall be identified and established prior to construction of any irrigation system. Each Public Open Space with an area greater than 4000sqm shall have its own water source.

Within subdivisions water supplies shall not be limited to any one water source, with each Public Open Space with an area greater than 4000sqm having its own water source. Groundwater, either groundwater retention basin or bore, shall be the preferred source of water for irrigation, however this requirement may be waived, at the discretion of the City of Swan, under extenuating circumstances.

1.2. Water Allocations and Licensing

All groundwater usage shall be licensed as required by the Department of Water and Environment Regulations and shall detail specific lots and areas to be irrigated.

A copy of this licence will be provided to the City of Swan along with proposed plans.

Ground Water Licence and Water Allocations shall be transferred to the City of Swan along with details of past water usage, bore construction and pumping equipment details as part of the “handover” process before being transferred into the name of the City of Swan.

1.3. Flow monitoring

All water sources shall have appropriate flow meters installed to monitor water usage. Further details relating to the specific requirements of flow meters can be located under Flow Meters section of this document.

2. Bore Construction

Bores shall be constructed in accordance with ‘The Minimum Construction Requirements for Water Bores in Australia’ February 2012, third edition, published by National Uniform Drillers Licencing Committee 2011 in relation to the bore construction, development and testing.

All Bores shall be located so as to give ample heavy vehicle access to allow for future servicing requirements and be located within the property boundaries.

2.1. Diameter and Depth

The diameter of the bore hole shall be adequate for the installation of the standard casing and gravel packing. Depth shall be as required and permitted by the Department of Water and Environment Regulations.

2.2. Verticality and alignment

The bore shall be drilled and cased straight and vertical with a maximum out of vertical tolerance of 100mm per 30 metres of depth.

2.3. Drilling Method

Bores shall be constructed using either cable tool or rotary mud drilling as required. The driller shall collect drill cuttings at 1.0 metre intervals, or upon changes in the formation. Samples should be used to develop a documented profile of the soil strata levels. This documentation should form part of any development application to the City of Swan.

2.4. Gravel Packing

The annulus surrounding the casing and screen shall be packed with 50-120mm thick washed well-rounded gravel of selective grain size and gradation from the static water level to the base of the bore hole. The annulus surrounding the casing shall be backfilled with drill cuttings from the surface to the static water level.

2.5. Casing

Bores shall be constructed using a minimum standard of 155mm Class 9 PVC-U pressure pipe. Where an artesian bore is being constructed to a depth of 120 metres or deeper, then casing should be constructed of FRP (fibreglass-reinforced polyester). Steel casing shall not be permitted.

2.6. Screen

Screen assemblies shall be constructed of 0.6mm aperture, Stainless Steel screen. NOTE: Slotted PVC screens shall not be permitted.

2.7. Test Pumping

Screen assemblies shall be constructed of 0.6mm aperture, Stainless Steel screen. NOTE: Slotted PVC screens shall not be permitted.

Test equipment must have capacity to pump at a rate equal to 150 % of irrigation design requirements.

Throughout the test a log containing the following data shall be maintained:

1. Reserve Name and Location
2. Bore Licence Number
3. Drillers Name
4. Date of Test
5. Bore casing diameter material
6. Diameter, mesh size, length and material of screen
7. Depth of bore to top of screen
8. Static Water Level prior to test
9. Pumping rate of water supply test
10. Drawdown from Static water Level at nominated continuous test rate
11. Depth to pump inlet
12. Water Level and flow rate readings during constant rate test as follows:-
 - 0 to 15 minutes - every minute
 - 15 to 60 minutes -every 5 minutes
 - 60 to 120 minutes - every 15 minutes
 - 120 to 600 minutes - every 30 minutes
 - > 600 minutes - every 60 minutes.

Results of these tests shall be forwarded to the City of Swan and the Department of Water and Environment Regulations upon practical completion of bore construction.

2.8. Yield

Bores shall be constructed to provide a yield a minimum 30 % greater than the requirements of the irrigation system they will be servicing.

2.9. Water Analysis

An air free water sample is to be taken at the completion of the water supply test for analysis (within 24hours) by a NATA approved laboratory capable of performing relevant tests.

Analysis shall include a complete report on the quality and suitability of the water for irrigation purposes and include the following information:

1. Reaction
2. Appearance
3. Colour
4. Odour
5. Total soluble salts
6. Total Alkalinity (as CA CO₃)
7. Iron as Fe in solution
8. Free carbon dioxide (by calculation)
9. Comments on the effect of water on iron and brass equipment and stain potential.
10. Nutrient analysis

2.10. Casing Termination

On completion of bore development and test pumping operations, the bore casing shall be cut to 100mm above finished ground level and fitted with a galvanized steel, drilled Table E flange and a blank galvanized steel top flange with rubber gasket, to prevent unauthorized access to the bore.

The bore casing shall be fitted with a casing clamp 200 mm to 300 mm below the flange. A concrete plinth shall be poured around the casing and shall finish level with the top of flange (100 mm above finished ground level). This plinth will form the base for the headworks assembly and consist of 20 mPa concrete poured to form a minimum 750 mm by 750 mm square and a minimum 600mm deep.

3. Pumping System

3.1. Pump

All Bore pumps shall be submersible type of a size and brand approved by the City of Swan.

3.1.1. Discharge Column

For submersible pumps, the discharge column shall consist of Class 18 PVC or Permaglass pump column with stainless steel couplings and two (2) stainless steel support cables.

A 20 mm continuous Polyethylene probe conduit shall be installed, terminating level with the top of the pump(s). The top end shall terminate with a 20 mm (Cat 17) valve socket, screwed into the 20 mm socket provide in the bore head discharge flange.

3.1.2. Drop Cable

Hydrofirm, Eucahydro or Aflex EPR/PUR cable, terminating in the bore head metal junction box. Column centralizers shall be installed at the pump and at a minimum of 12 metre intervals of columns to protect electrical cables. The probe conduit (to be continuous 20 mm polyethylene), the pump cable and the drawdown tube shall be installed and clipped to the column at regular intervals. Allowances shall be made for any likely expansion or twisting of the pump column.

The probe conduit shall be installed in such a way as to ensure that the two-wire probe can be moved freely within the conduit for adjustment.

3.2. Headworks

For the purpose of this specification, the term Headworks (Discharge Assembly) shall refer to the pipework and associated components from the top of the bore casing through to the underground connection to the PVC mainline.

Bore Headworks specifications are subject to change and all headworks are to comply with latest DWER (Department of Water and Environmental Regulation) requirements at time of handover, not practical completion.

3.2.1. Components

The headworks or discharge assembly shall contain as a minimum but not limited to the following key components:

Wafer check valve of equal diameter as piping.

Flanged test tee with matching blank flange of equal diameter to piping;

Butterfly isolating valve (located after test tee).

Flow meter.

All above ground pipework shall be constructed of hot dipped; galvanized Schedule 40 ERW fabricated steel and be butt weld flanged type, unless otherwise stated.

All butt weld elbows shall be of the long radius type.

The complete assembly shall be as per attached diagram clause 9.1 Bore Headworks / Discharge and Flow Meter Assembly.

3.2.2. Bore Headworks Junction Boxes

Two galvanized metal electrical junction boxes are to be installed opposite each other on the top of the first discharge assembly flange. One box is to be for the pump supply cables, the other for

the probe and drawdown tubes. The pump electrical supply cable, 4 mm draw down tube and the two wire, low level probe wires, shall all pass through Heavy Duty Electrical Grade electrical conduits (minimum diameter 32mm), installed in the concrete plinth and terminating in the junction boxes.

The probe wires, pump cable and draw down tube shall all pass through propriety glands or bushes installed in the junction boxes. Cables passing through plain holes will not be accepted. One junction box shall be equipped with a brass earth stud for the earthing of the assembly in accordance with Western Australian Electrical Requirements.

Ref to attachment diagram in clause 9.2 Bore Headwork Junction Box.

3.2.3. Pressure Take Offs

A ¼ inch BSP tapping into the discharge pipe (near the point of connection to the mainline) shall be installed and connected to pressure tubing run to the electrical cubicle for attachment to relevant sensors.

3.3. Filtration

Any Iron filtration systems and/or inline filters shall be assessed individually at the time of submission for approval. The submission shall include detailed plans of all iron filtration system and/or inline filters of make; model; size; layout; service life; and servicing requirements/costs.

All iron filtration systems shall be within an Enclosures (with a roof) to prevent unauthorized access, all Enclosures types shall be assessed individually at time of submission.

3.3.1. Irrigation Tanks

All proposed irrigation tanks to be utilised as a water source for irrigation shall be assessed individually at the time of submission for approval. Concrete tanks are the City's preference; however, under certain circumstances on city approval, other material such as steel industrial tanks maybe used.

3.3.2. Pumping Stations

All proposed Pumping station and/or a single point of water source used to irrigate multiple sites; shall be assessed individually at the time of submission for approval. All information on the construction /configuration of the pumping station shall be provided to include, but no limited to;

Proposed areas of irrigation

Design configuration – Variable drive units, sine wave filters etc.

Enclosures (with roof) and fencing type around the site

Access to site – future servicing

needs Predicated running cost -

yearly Future service requirements -

yearly.

4. Electrical Works

4.1. Power supply

A constant, underground, 415/240 Volt, 3-phase, 50Hz mains power supply for all cabinets associated with an irrigation bore and/or pump.

Where a cabinet is installed for the sole purpose of supplying power to an irrigation controller only an Un-metered Power Supply may be established. This supply shall be maintained throughout the maintenance period and account ownership transferred to the City of Swan as part of the Handover process of the site.

No mixing of AC Power cabling & Reticulation rated cabling is permitted.

4.2. Electrical Cabinet/Cubicle

A standard City of Swan Irrigation Electrical Cubicle shall be installed at all sites having either a pump system or irrigation controller installed, refer to 4.2.2 of these specifications.

Refer PGS Industries Drawing 15787-1 & 15787-2.

4.2.1. Location

Electrical Cubicles shall be located so as to allow unobstructed access from a constructed road or car park, facing away from main irrigated area and orientated so as to ensure no direct water jet from surrounding sprinklers shall strike the cubicle.

Electrical cubicle shall be located within property boundary and no more than 30 metres from the bore or pump headworks, to allow for connection of flow meters, etc.

4.2.2. Cubicle Construction

Refer to PGS Industries Drawing 15787-1 & 15787-2

4.2.3. Base

Cubicle shall be secured with 316 stainless steel “Chemset” anchor bolts to a concrete plinth, min. 20Mpa strength.

The top of the plinth shall be set 100 mm above finished ground level and extend a minimum of 600 mm below finished ground level. The top of the plinth shall extend beyond the cubicle by at least 100 mm on all sides and shall angle away so as to prevent the accumulation of water against the base of the cubicle.

Conduits shall be installed in the concrete base so that they enter the cubicle behind the control panel. Additional spare conduits, two X 50 mm, and, two X 25 mm, shall be installed and fitted with long radius bends. Conduit stubs shall be extended at least 100 mm beyond the concrete plinth and terminate within a cable pit.

4.2.4. Aerial Pole

All electrical cabinets associated with irrigation control shall have an 80mm (Diameter) x 6.5 metre (Height) Medium Duty Galvanized Steel Pole installed between a minimum of 1 metre and a maximum of 20 metres from the cubicle. This pole shall be installed so as to minimise obstruction in the area and maximize communication signal strength as per this specification.

4.3. Electrical Components

4.3.1. Switch Board

The cubicle shall contain a minimum of:

- Main Switch

Supply and Other Circuit Fuses

Motor Starter

Three position key switches (auto, off, manual) with key removable in the off (centre) position only.

Two (2) General Power Outlets (GPO)

A Rainman Mps Irrigation Controller as per below Specifications

Ammeter

Western Power Corporation Meter Panel

A Mainline Pressure Gauge

Pre filter (where fitted) pressure gauge

Hour Meter

Bore pumps are to have a minimum of the following protection:

Phase Failure Relay

Motor Manufacturer's Recommended Overload Relay

Low Water Level Detected by Two Wire Probe in Bore

4.3.2. Control Panel

The control panel shall be suitable for a prospective fault current of 9kA and accommodate all control and monitoring equipment for the operation of the irrigation pump and controller.

The minimum standard for internal wiring is V75 stranded (1.5 mm²).

All connections to the internal wiring shall be to a terminal strip, numbered to correspond with a schematic diagram. One, laminated, copy of the "As Constructed" wiring diagram is to be placed in the document holder placed inside the cubicle door and one additional copy is to be handed to the Superintendent.

Wiring shall be neat and unobtrusive, cleated in vertical and horizontal runs and installed without any interposed joins.

A labelled terminal strip (able to accommodate three valve wires) is to be provided, for the termination (and bridging if required) of the field valve wiring. This terminal strip is to be wired to the controller outputs. Labelled terminal strips are to be provided for the rain switch and low level probe terminations.

Cubicles associated with pump systems shall be fitted with fault indicator lights (which must indicate in bright sunshine), reset button(s) and manual off/auto switch.

The ammeter shall be a minimum of 70 mm square and shall have a red line to indicate the full load current of the pump motor. The scale shall be such that the full load current shall be approximately at the middle of the scale.

4.3.3. Motor Starting Equipment

A Western Power Corporation approved soft starter capable of 12 starts per hour is to be installed.

The starter and contactors shall:

- Be selected for electrical utilization category AC36.
- Have auxiliary contacts, as required, to provide the specified control and interlock functions.
- Be equipped with auxiliary contacts of a minimum rating of six Ampere. If it is impractical to include
- The required auxiliary contacts on the main contractor, an auxiliary relay may be installed.
- Be provided with a pump rated circuit breaker.
- Comply with the requirements of Australian Standard Specifications as appropriate for contactors, Starters, overloads, relays and so forth.

Contactors, timers, relays and ammeter are to be housed in a dust proof enclosure or be protected by a well-fitting escutcheon panel to the superintendent's satisfaction.

The escutcheon panel shall be fabricated, and aluminium hinged as per attached diagram (9.3). It shall be fitted with at least two lifting handles. It shall be provided with cut-outs which expose only toggles and dollies.

4.3.4. Fault Current Limiters

Fault current limiters shall be incorporated, where necessary, to limit the prospective fault current to a value within the capacity of the equipment being protected and be clearly labelled "Fault Current Limiters," together with the make, type, rating and catalogue number of the limiter on the label.

4.3.5. Circuit Breakers

Miniature over current circuit breakers, if required, shall be a minimum of 6kA rated and comply with the requirements of AS 3111 and/or AS 2184, as applicable. They shall be DIN rail mounted and fitted with suitable covers, if required by the Superintendent.

4.3.6. Residual Current Devices

Residual current devices shall be installed and shall comply with AS 3190 and have a sensitivity of 30mA.

4.3.7. Switches and Isolators

All switches and isolators shall comply with AS 3133, class “M” or “X” as applicable and be suitable for their intended use and be mounted in accessible positions. Contacts shall have a minimum 10 Amp rating.

4.3.8. Voltage Transformer

A 240 Volt to 24 Volt transformer is to be provided to power the controller and other equipment as required. Transformers shall be a minimum rated 100VA and be double wound type with an earth screen interposed between the primary and secondary windings.

They shall be enclosed, A-N type with coils either vacuum impregnated using varnish to BS 2778 or resin encapsulated. All transformers shall be acceptable by the controller manufacture for both type and location.

4.3.9. Pump Circuit Breaker

Motor Pump Circuit Breakers shall be thermal type and provided in each phase and as approved by the motor manufacture for the protection of the motor in its installed situation.

Circuit Breakers shall be compensated for ambient temperature and if of the adjustable type, have a minimum adjustment from 70 to 105% of full load current.

4.3.10. Controller

Aquamonix Pty Ltd manufacture of Rainman controller is to be supplied and installed as per this specification.

The inputs/outputs shall be direct connected to the controller.

4.3.11. Fans/Heaters

All cubicles are to be provided with a cooling fan.

The fan shall be of the sandwich type and be sized to be able to expel the volume of air in the cubicle at least four times per hour. The fan shall be installed directly under the top vent and shall be thermostatically controlled.

Cubicles exposed to condensation shall have one “Helois” 70-watt, anti-condensation heater, per 2m³, located near the bottom of the cabinet and thermostatically controlled. Thermostat control must be located where retic staff can gain access.

4.3.12. Surge Suppression

All equipment shall be designed, suitable for withstanding any over-voltage which might develop in the installation, be equipped, where necessary, with suitable non-linear resistors (surge diverters) to attenuate the effects of over voltages and comply with the relevant Australian Standards.

4.3.13. Interference

The installation shall also include equipment, if necessary, that limits voltage fluctuations and harmonics. All equipment shall be designed not to emit electromagnetic interference or shall be equipped with electromagnetic interference suppression.

If necessary, equipment shall be equipped with radio frequency filtering (RF) to ensure that radio and television reception is not interfered with near the site.

4.3.14. Earthing

The earthing of the installation shall be arranged for the Multiple Earthed Neutral system, comply with Australian Standards wiring rules AS 3000 and any additional requirements of the Supply Authority.

Earthing shall be by “Copperweld” earth electrode driven to a depth of 1.4 metres in a FC4 main earth pit or similar, installed outside the cubicle and preferably in the wetted zone of the sprinklers. It shall have copper earthing conductors and bond all metallic water pipes and so forth within 2.5 metres of the installation.

Earthing shall also effectively earth all metallic escutcheons, doors and so forth and incorporate an earth busbar or link(s), sized to suit all earth conductors.

4.3.15. Cable Pits

1 x type 77 ACO plastic pit (cat no 76344) with steel powerloc lid (cat no 77730) is to be installed for power conduit access to reticulation cubicle (cabinet).

Install 3 x 63mm manufactured bends (no flexible conduit is permitted) from reticulation cubicle concrete slab to type 77 plastic pit. This will provide access for power cabling from type 77 pit to reticulation cubicle. Conduits are to be fully accessible behind cubicle escutcheon cover and enter left hand side of cubicle for access to mains power side of switchboard.

Earth rod inspection pits to be durable plastic base with plastic lid. Lockable durable type with 2 x Ellen key stainless steel bolts as per manufactured item. 1 x type 3 ACO plastic pit (cat no 75865) with steel powerloc lid (cat no 70330) is to be installed for reticulation cabling conduit access to reticulation cubicle (cabinet).

Install 3 x 50mm manufactured bends (no flexible conduit is permitted) from reticulation cubicle concrete slab to type 3 plastic pit. This will provide access for reticulation cabling from type 3 pit to reticulation cubicle.

Conduits are to be fully accessible behind cubicle escutcheon cover and enter right hand side of cubicle for access to reticulation equipment side of switchboard. Pits to be set flush with finished original ground level.

All electrical conduits to be at a minimum depth of 500mm with danger warning tape at no lower than 250mm below surface. No power 240V or 415V cable joints permitted anywhere within installation.

3M red marker balls are required in all cable pits.

4.3.16. Labelling

All electrical components shall be labelled as to their designation and function.

Labels shall be manufactured from “Traffolyte” or similar material, fitted to the front of each panel and secured to the equipment using at least two chrome plated, round head screw fixings which will permit ready replacement. Labels shall be machine engraved with minimum three (3) mm high characters.

“Danger” labels shall be red lettering (6 mm min.) on white background.

Main Control Labels shall be black lettering (6 mm min.) on white background.

4.3.17. As Constructed Drawings

The Contractor shall provide two sets of “As Constructed” drawings of all control and protection circuits together with all information necessary for the operation, maintenance, and replacement of equipment. Plans should include the conduit allocation and direction of all conduits.

One set of these documents shall be housed in the door pocket, one set handed to the Superintendent at handover.

4.3.18. Operation

The bore motor can be manually started by selecting “Manual” position on the selector switch.

In order for the bore motor to be controlled automatically by the irrigation controller, the “Auto” position must be selected. A key lockable isolation switch shall be installed to permit future “tagging” during repairs or maintenance.

5. Irrigation System

5.1. Design

City of Swan Irrigation systems shall be designed to utilize the key components as identified in this specification in order to ensure uniformity with other City of Swan irrigation systems.

This is required to minimize all costs and availability associated with spare parts. All irrigation systems shall be designed to hydro-zoning principles. Sporting Ovals shall be divided into two zones, active and passive.

The active area shall be the playing surface and shall be valved and have sprinklers installed separately to any passive area. For non-sporting ovals (Passive Parks) the turf and garden areas are to be design to be irrigation separately.

5.1.1. Efficiency

Irrigation systems shall be designed so as to maximize the coefficient of uniformity to enable optimal watering efficiency.

The distribution uniformity (DU) of 80% is the minimum requirement of all irrigation designs.

Systems shall be capable of meeting plant water requirements by operating only between the hours of 10 pm and 6 am, for a maximum of five (5) days per week, where practicable. Licensing requirements currently dictate no watering is to occur between the hours of 9 am and 6 pm daily.

5.1.2. Stations

Irrigation systems shall be designed so as to ensure a single use for each station, for example: turf only; gardens only; tree bubblers only.

Each individual station shall be designed for the use of one single method of delivery, i.e. one type of sprinkler, no mixed stations shall be accepted. All retic in garden beds must be designed to allow full coverage of water once plants have reached maturity. Each station must have the ability to be individually tested.

NOTE: Tree bubblers are intended to be used for newly planted trees up to a maximum of two years from practical completion before being phased out due to establishment of the planted trees. All tree bubblers shall be installed as separate stations.

Under no circumstances are tree bubblers to be installed as part of a sprinkler line.

5.1.3. Format

Proposed Irrigation System plans shall be submitted to the City of Swan in both hard copy and electronically utilizing CAD based software.

“As Constructed” Irrigation System plans shall also be provided within three months of the practical completion date of the specific site.

5.2. Conduits

Piping or control cabling to be installed under existing or future roadways or pathways shall be installed within PVC sleeving and be constructed of SWJ PVC Pipe as required by these specifications. Separate conduits shall be required for piping and control cabling.

PVC sleeving shall be of a size at least 30% larger than the outside diameter of the pipe coupling and/or control cabling to be installed within. The conduit is to continue a minimum of 600mm past the finished edge of the roadway or pathway and be of sufficient depth to ensure a minimum of 600mm depth from finished ground level. Any such conduits shall be clearly marked and identified on “As Constructed” plans.

In locations of extreme limited space and/or access, the use of a shared single conduit maybe allowed under these circumstances however, City approval for a shared conduit will be required and must be highlighted and noted on all submitted drawing. A shared conduit sleeving shall be of a size at least 40% larger than the outside diameter of all pipe coupling.

Note: Control cabling shall require to be within its own conduit when placed into a shared location.

5.3. Mainlines

For the purpose of this specification the term “Mainline” shall refer to all pipework and associated fittings up to but not including the Solenoid Valve Assembly.

5.3.1. Mainline Pipes

All underground mainlines shall be constructed of a minimum of Class 12 uPVC Piping. Piping of 80mm size or larger shall Class 12 PVC RRJ (Rubber ring joint) as a minimum. The City’s preference is for Series 1 piping but may consider Class 2 on request.

Where mainlines and/or lateral lines that are required to be installed under a roadway, one continuing length of PE piping in conduit will be required. PE Piping may also be used in other locations where there are concerns due to close proximity to other services within the verge. All use of PE piping as a mainline and/or lateral line within a verge shall require City’s approval.

Mainline piping up to and including 50mm in size shall be Class 12 PVC SWJ (Solvent weld jointed). All mainlines shall be jointed strictly in accordance with the manufacturer’s specifications.

Any mainline installed within an easement lot shall be required to comply with the managing authority requirements.

5.3.2. Mainline Fittings

All mainline fittings up to and including 50mm in size shall be Class 18 moulded pre-fittings and be solvent cement jointed.

Mainline fittings 80mm or larger in size shall be as follows:

- Bends less than 90° angle shall be PVC rubber ring jointed long radius.
- Bends or elbows of 90° angle shall be Rubber Ring Joint, Ductile Iron.
- All tees are to be Rubber Ring Joint, Ductile Iron.
- All reducers to be concentric, Rubber Ring Joint, Ductile Iron.
- Flanged connectors are to be Rubber Ring Joint, Ductile Iron or PVC with galvanized backing ring.

All Flanges are to be pre-drilled Table E Flanges.

5.3.3. Mainline Isolation Valves

Mainline isolation valves shall be installed at all significant changes in direction, each side of road crossings (if the mainline is NOT installed within an underground conduit) and every 500m on straight lines.

Isolation valves shall be Ductile Iron, resilient seated gate valves (with spindle and configured for clockwise turning to close valve) and be of equal size to the mainline in which they are installed. Where mainlines are 50mm or smaller isolation valves shall be Philmac nylon ball valves of equal size to the mainline in which they are installed.

All valves that are not located within a non-hardstand area e.g. (concrete footpath) shall be installed within a valve box and marked with a 3M orange marker ball. All valves located within a hardstand area e.g. (concrete footpath) a 3M orange marker ball is not required however, the valve lid must be clearly marked indicating mainline isolation value.

5.3.4. Air Release Valves

Air release valves shall be fitted at end of lines and at identified high points in the installation.

All air release valves below ground shall be installed as per attached diagram utilizing brass tapping band, Philmac nylon isolating ball valve and Philmac nipple. For mainlines 80mm and larger air release valves shall be 2” Philmac dual action air release valves. For up to and including 50mm the valve shall be a 1” Philmac dual action Air Release valves.

All valves below ground shall be installed within a valve box and marked with an orange 3m marker ball.

Ref to drawing attachment clause 9.4 Air Release Values.

5.3.5. Thrust Blocks

Concrete thrust blocks shall be installed on all Rubber Ring Joint fittings and as required on mainlines, including elbows, bends, reducers, tees and isolation valves.

Thrust blocks will not be required for “self-straining” fittings such as those fitted “inline” and tapping bands. Thrust blocks shall be constructed symmetrically about the centre line of the fittings and shall be placed so as all pipe joints are accessible for inspection and/or repair. Pipe, fittings and cabling shall be covered with a protective membrane of plastic sheeting when adjacent to concrete surfaces.

Thrust blocks shall have minimum dimensions of approximately 600mm by 600mm by 600mm and with all sides being either formed or placed against undisturbed soil faces to ensure clean edges. Concrete shall be minimum 20 mPa and be thoroughly mixed prior to installation.

Dry concrete mix and water shall not be mixed in the trench.

5.3.6. Installation requirements

Mainlines shall be installed so as to ensure a minimum of 450mm soil covering between the top of the mainline and the finished soil surface, with the exception of pipes under roadways, where the minimum covering depth shall be 600mm. Pipes shall be laid into trenches having a continuous, firm and relatively smooth base, free of rocks, rubble or sharp objects.

When installed in areas that cannot meet this requirement the pipe shall be bedded onto and covered with a minimum 100mm layer of sand to avoid any pipe contact with rocks, rubble or sharp objects.

Trenching shall be straight and of a width sufficient to enable a minimum of 100mm space between any additional pipes installed within the same trench. Under no circumstances shall separate pipes touch within the trench. All trenches shall be filled with the excavated soil and be plate compacted after filling to minimize any potential subsidence in the future.

No debris (off cuts of pipe, etc....) shall be buried in trenches during the construction of the site. On active surfaces (sporting fields) all pipe works must be a minimum of 350mm in deep, this is to allow for future surface renovation works.

5.4. Cabling

5.4.1. Conventional Type Cabling

Conventional field wiring of all irrigation systems shall consist of multi wire systems and include a minimum of two spare cables or ten percent of the total number of stations, whichever is greater, run from the controller to the furthest point of each mainline including spur lines .

5.4.2. Size and Type for Conventional Cabling

All low voltage (24 Volt) solenoid control valves shall be Tyflo multi-strand copper conductors sheathed in polyethylene suitable for direct burial. Minimum cable sizes shall be:

- Common Wires - 2.5mm 2 conductor
- Active Wires < 400m - 1.5mm 2 conductor when cable run is shorter than 400m.
- Active Wires > 400m - 2.5mm 2 conductor when cable run is longer than 400m.

In order to ensure reliable valve operation, all cabling within trenches must not be pulled tight. A different colour cable shall be used for each active wire, with an individual cable being installed to each valve.

Common wires shall be black, spare wires shall be white. At each solenoid valve a minimum 1.5m loop of both common and active wires shall be installed neatly within the valve box to allow for future works. Cabling shall be run in conjunction with mainline installation and shall be neatly bundled and taped at approximately 4m intervals.

Care should be taken to place cables below or immediately beside mainline without being taped to pipes. Where cabling is not run in conjunction with the mainline it shall be installed within PVC conduit as per conduit specifications.

5.4.3. Connection for Conventional Cable

All field wiring cable connections, including solenoid valve connections, shall be made within a marked valve box using 3M DBY or DBR direct bury splice kits. All valve boxes shall include a 3M orange marker ball for future location. Spare wires shall also be terminated using the same direct bury splice kits.

Note: soldering of wire connections will not be accepted.

5.4.4. Junction Boxes

All cable joints or end of cable runs shall be made within a clearly marked and identifiable cable pit and shall have a minimum of 2m of spare cable looped neatly within the pit. All Pits shall include a 3M orange marker ball for future location.

These pits shall be identified on the "As Constructed" plans.

5.5. Solenoid Valve Assembly

Solenoid valve assemblies shall be comprised of the following components;

- tapping band
- polyethylene nipple(s)
- electric/hydraulic solenoid valve
- PVC valve socket
- PVC "Slipfix" fitting.

Bronze Tapping Bands shall be used to connect Solenoid Valve Assemblies to the mainline and shall be of equal size to the valve to which they will connect. Solenoid Isolation Valves shall be Philmac nylon ball valves of equal size to the solenoid valve. Connections between valves and tapping bands shall be made using threaded polyethylene nipples.

All threaded connections shall be sealed with the use of PTFE Thread sealing tape.

Electric/hydraulic solenoid valves shall be normally closed 24 Volt (AC), 50 cycle, Bermad 200 series (including flow control) or Bermad 400 series only and shall include a manual bleed facility.

A Flo span "slip fix" repair coupling of equal size to the valve, shall be jointed to a Cat 17, PVC valve socket (Cat 17) to allow for future servicing requirements.

Solenoid Valve assembly shall be installed as per attached diagram.

5.6. Valve Boxes

All valves, including mainline isolation valves; air release valves; solenoid isolation valves; solenoid control valves, shall be installed within a lockable valve box Mainline Isolation valve boxes shall be HR Products "Jumbo" Valve Box, Model 1420-12VBHR (or approved similar).

Solenoid Valve & Air Release Valve boxes shall be HR Products Model 1419-12VBOL (or approved similar) without pipe portals and with overlay style lockable lids with stainless steel locking bolts. Valve Boxes shall be installed so as to have the overlay style lid finishing flush with the final soil level and shall ensure valves are readily accessible for servicing without removal of box as per the attached diagram.

All valve boxes, wiring pits, isolation valves, air release valves shall have a 3M Orange ball marker installed between the valve and the lockable lid to facilitate future locating requirements.

5.7. Lateral Lines

For the purpose of this specification, lateral lines shall refer to all pipelines and associated fittings downstream from the Solenoid Valve Assembly, up to but not including the sprinkler and its riser.

5.7.1. Pipes

Lateral lines shall be constructed of a minimum of Class 9 uPVC Piping. All joins in pipework and fittings shall be by Solvent Weld Joint (SWJ) and shall be constructed strictly in accordance with the manufacturer's specifications. This includes the cleaning of all sized joints with approved primer prior to assembling.

5.7.2. Fittings

All lateral line fittings shall be Class 18 moulded pre-fittings and be solvent cement jointed, in accordance with manufacturer's specifications. Any excess solvent cement shall be wiped clean from pipes and fittings.

5.7.3. Installation Requirements

Lateral Lines shall be installed so as to ensure a minimum of 350mm soil covering between the top of the lateral line and the finished soil surface, with the exception of pipes under roadways, where the minimum covering depth shall be 600mm.

Pipes shall be laid into trenches having a continuous, firm and relatively smooth base, free of rocks, rubble or sharp objects. When installed in areas that cannot meet this requirement the pipe shall be bedded onto and covered with a minimum 100mm layer of sand to avoid any pipe contact with rocks, rubble or sharp objects. Trenching shall be straight and of a width sufficient to enable a minimum of 100mm space between any additional pipes installed within the same trench.

Under no circumstances shall separate pipes touch within the trench.

All trenches shall be filled with the excavated soil and be plate compacted after filling to minimize any potential subsidence in the future.

5.8. Sprinklers

In order to maintain a standardized irrigation network across the City of Swan this specification provides a standard range of sprinklers to be utilized when designing irrigation systems.

Any use of sprinklers outside of those listed may be approved with the express written consent of the City of Swan at the time of assessment. Sprinklers shall be full circles where required and adjustable or part circle on edges. Adjustable sprinklers (adjusted to full circle) shall not be installed where a full circle sprinkler is required.

5.8.1. Size and Type

The following gear driven sprinklers shall be utilized as required:

- Hunter I-41 Series -
 - I-41: 9 cm pop up (Full Circle or Adjustable) sprinkler
- Hunter I-35 Plus Series -
 - I-35: 9 cm pop up (Full Circle or Adjustable) sprinkler
- Hunter I-20 Ultra Series -
 - I-10: Shrub (Full Circle or Adjustable) Sprinkler
 - I-20: 10 cm pop up (Full Circle or Adjustable) sprinkler (Stainless steel riser)
 - I-20-6P: 15 cm pop up (Full Circle or Adjustable) sprinkler (Stainless steel riser)
 - I-20-HP: 30 cm pop up (Full Circle or Adjustable) sprinkler
- Hunter PGJ Series -
 - PGJ - 00: Shrub (Full Circle or Adjustable) sprinkler
 - PGJ - 04: 10 cm pop up (Full Circle or Adjustable) sprinkler
 - PGJ - 06: 15 cm pop up (Full Circle or Adjustable) sprinkler
 - PGJ - 12: 30 cm pop up (Full Circle or Adjustable) sprinkler

The following spray type sprinklers shall be utilized in smaller areas as required:

- Toro 570 Series –
 - 570Z-S: Shrub Adaptor
 - 570Z-3P: 75 mm pop up sprinkler
 - 570Z-4P: 100 mm pop up sprinkler
 - 570Z-6P: 150 mm pop up sprinkler (No side inlet)
 - 570Z-12P: 300 mm pop up sprinkler (No side inlet)

Toro MPR Plus spray nozzles shall be utilized with Toro 570 sprinklers.

Toro 500 Series Flood Bubblers or approved equivalent, on 15mm poly risers, shall be utilized for tree bubblers. All sprinklers available with non-drain valves as an option shall have such valves installed.

Sub surface or drip irrigation maybe utilized in garden bed areas depending of water quality, this type of irrigation will require City approval.

5.8.2. Risers

All Sprinklers shall be installed on adjustable articulated risers, consisting of 3 threaded poly elbows and a straight poly riser of equivalent diameter to the inlet thread size of the sprinkler. Length of the articulated risers shall be sufficient to ensure the riser is inclined at an angle of 45o to the horizontal when installed is complete.

“Funny” pipe (Olsen EZ-EL or similar) may be used for spray type sprinklers only, as required and shall at no time be utilized for gear driven sprinklers.

5.8.3. Height and Adjustment

Sprinklers shall be set as per attached diagram with the top of the sprinkler being set flush with finished ground level, as per manufacturer’s specifications.

Sprinklers should also be set straight to the vertical alignment, except when installed on significant slopes where the sprinkler shall be set halfway between the vertical and the angle of the slope on which it is installed. When installed beside roadways or footpaths, sprinklers shall be installed so as to be 150 mm from the nearest kerb line. Sprinkler arcs shall be adjusted to ensure minimal overspray onto nearby roadways or fixtures occurs.

6. Irrigation Control System

The City of Swan operates a centrally controlled Irrigation network to monitor its irrigation operations throughout the City. All new systems installed by the City, or to be taken over by the City (eg new developments) are to be constructed as per the following specifications.

Practical completion dates shall not be considered effective until all the networks and components are communicating to the City of Swan Central Irrigation Control Computer.

6.1. Controller

All irrigation systems shall be operated by a Rainman controller as manufactured by Aquamonix and shall include inputs for all required components to fulfil the required specifications as detailed below. The controller shall be capable of operating the maximum number of stations and shall be housed with the electrical cabinet as per this specification.

6.2. InField Communication / Design and Configuration

All communications to the City of Swan Central Irrigation Control System shall be connected as specified,

- All sites required to communicate with the central irrigation system shall be via 4g/5g modem. All equipment, installation and configuration requirements shall be provided by the Rainman software vendor, Aquamonix. Developers will be required to provide all sim cards/network providers during allocated maintenance period. Once handover process has been approved by the City, the City will arrange for sim card replacements to its current network provider.

All sites must communicate with the City central irrigation system during the Developer’s maintenance period.

Some locations within the City there may be limited 4g/5g network coverage which may cause poor communication between central irrigation system and sites. In this instance where a constant 4g/5g communication cannot be achieved by any network provider, the Central Hub Design will be required. City approval to utilize this communication method will be required prior to any installation.

- Central Hub Design and Configuration:

A central hub configuration shall be a single point of contact within a given 3 km radius area within a subdivision. This hub shall communicate via a 4g/5g modem back the City’s central computer.

All

data from the remote/outer sites shall communicate from this point. A maximum of 30 remote/outer sites will be allowed to connect to single hub.

Where a central hub is not available within a 3km radius and/or the current hub is fully utilized, a new central hub will be required to be installed. When choosing the location for a new hub, consultation and approval with an Aquamonix representative shall be required.

- The radio transmitter/receiver shall be an Aquamonix Elpro 905U-D and connected to a 10m split pole mounted RF Industries COL84-930 antenna via RF Industries RG 58-9006 communications cabling.

All requirements, equipment and configuration for a central hub set up can be obtained through Aquamonix.

- Remote/outer sites design and configuration:

All remote/outer sites within the 3 km radius of a central hub shall communicate via a radio network to this hub. All requirements, equipment and configuration for the remote/outer sites set up can be obtained through Aquamonix.

- The radio transmitter/receiver shall be an Aquamonix Elpro 905U-D and connected to a pole mounted RF Industries YB806-94 antenna via RF Industries RG 58-9006 communications cabling.

An example of a Central Hub design diagram is shown in clause 9.5 drawing/attachment.

All communications equipment shall be compliant with relevant Australian

Communications

Authority regulations. The antenna shall be installed so as to maintain a reliable signal to the chosen central hub and be as unobtrusive as possible. All radio equipment shall be installed neatly within the cabinet and secured so as to ensure no loose cabling interferes with other components.

6.3. Sensors

All Irrigation control systems must include the following sensors to be installed and connected to the controller:

Pressure Transducer – Aquamonix PT10.10, to be installed within the cabinet to pressure tubing from the mainline (as per headworks specifications).

Rain Sensor – Aquamonix iC Rain (Ordering code ICR.G), to be pole mounted on the aerial pole.

Current Transducer – IMO MAC022PROG42, to be installed within the electrical cabinet.

6.4. Flow Meters

All bores and/or ground water sources used for irrigation and/or other purposes shall be fitted with the an approved flow meter as listed

- Aquamonix Magnetic Flowmeter
- Aquamonix Mag-S1
- Aquamonix Mag- B1
- Aquamonix Mag-X2

All flow meters must communicate with the City of Swan Central Irrigation Control System.

All flow meters shall be installed as per the manufacturer's specifications and a testing tee configuration as shown within clause 9.1 Bore Headworks / Discharge and Flow Meter Assembly.

6.5. Lightning/Surge Protection

All irrigation components that communicate directly with the controller unit onsite (Rainman MpS) must All irrigation components that communicate directly with the controller unit onsite (Rainman MpS) must be protected by a lightning/surge protections system.

The following lightning protection equipment must be installed as required by the manufacturer and comply with Rainman MpS controller requirements as indicated. For further information on obtaining these components, please contact Aquamonix.

The attachment diagram in clause 9.6 Lightning/Surge Protection illustrates the required protections.

Mains Power:	Critec TDS150-1S(R)-277 surge diverter
Field Wiring & Sensors:	Critec UTB-60SP 2 signal line protection module
Radio Antenna / Pole	Critec CSP1BNC90 coaxial surge diverter
Cellular Communication	Critec DEPRS23299D RS232 Serial Lightning Protection or Critec UTB- 60SP RS485 Serial Lightning Protection

6.6. Central Irrigation Control System Connection

Upon commissioning of all irrigation systems, it shall be compulsory to allow for connection of all site to the Cities Central Irrigation Control System; and that all functions, including communications, reporting and other requirements are fully functional and can be verified by the Cities representative.

This connection to the Cities Central Irrigation Control System is to be maintained throughout the contractor's maintenance period.

6.7. Two-Wire Irrigation Systems Requirements

Two wire decoder systems shall only be installed with the express written consent of the City of Swan.

All Two-Wire systems must be installed to the manufacturers specifications. A maximum of 96 decoders shall be permitted per Rainmain controller. No two (2) decoders must be programmed with the same number/address; each decoder shall be identified individually. Refer to 9.7 TWIN Field Cable Sizing chart to determine total number of decoders per cable length and size.

All two wire paths must NOT BE LOOPED, instead it should be a continuous length of cable with tees sections where required and cable termination on all ends.

Note: soldering of wire connections will not be accepted.

When installing a Rainman TWiN irrigation system the following equipment must be installed as required by the manufacture. For further information on obtaining these components, please contact Aquamonix.

Power Supply:	Aquamonix 60Hz Filtering Power Supply
(PSU.28VAC.12VDC) Grounding:	Aquamonix Grounding Kit (TW.GND.KIT)
Cable:	Aquamonix TWiNtrax Cable
Cable T Joins:	DBY/R
Decoder Connectors:	Cable Connector 1.5mm ² (BVS1) & Cable Connector 4mm ² (BVS2)
Cable Terminators:	Aquamonix Line Termination Unit (LTU.1)
Decoders:	Aquamonix TWiNcoil (TWC.L) or Aquamonix Decoders (TW.D.SO)

7. Commissioning

7.1. As Constructed Plans

"As Constructed" Irrigation System plans shall be provided to the City of Swan within three months of the practical completion date, in both hard copy, electronically in DXF and PDF file format.

A copy of the "As Constructed" electrical plans, bore construction details, flow test results including flow meter certificate of compliance shall also be supplied at this time. Upon handover to the City, these drawings are to be resubmitted to the City of Swan as stated in clause 8, Handover Procedure to the City of Swan.

All valves in as constructed plans must be clearly numbered.

7.2. Training

Site-specific training, relating to any particular areas of maintenance shall be supplied to City of Swan upon request at the time of handover to the City.

An example of this may be a specific filtration system or other such component of the irrigation infrastructure to which the City of Swan staff may not be familiar.

8. Handover Procedure to City of Swan

A formal handover procedure is required by the City of Swan. The bore, irrigation system and any ancillary equipment must operate to the satisfaction of the City of Swan. Any changes to the irrigation system during the maintenance period by the Developer will need to be recorded in the appropriate drawings or information sheet. This information shall be forwarded to the City during handover procedure.

Further information on each component is explained in this clause.

8.1. Testing Requirements

During the Handover procedure, the City must have the ability to isolate and test each individual irrigation station within an area. During this test, the City will note any defects with valves, controllers, sprinklers and/or any other irrigation infrastructure at the site. The system must operate to the satisfaction of City Officers prior to acceptance of Handover.

8.2. Water Allocation

All irrigation systems that abstract ground water as its main water source within the City of Swan, must have a Water Allocation Entitlement as per the Department of Water and Environment Regulation. All water allocation must be transferred to the City of Swan on acceptance of handover by the City.

8.3. Transfer of Water Entitlements

The Water Entitlement transfer form shall be provided by the Department of Water and Environment Regulation. Application for the transfer of water entitlements OR transfer of water licence must be completed provided at handover once accepted by the City.

This form shall be completed, signed by the authorised person and provide a payable cheque or other payment methods to the Department of Water and Environment Regulation for the amount stated on the application for the Transfer of Water Entitlement form.

8.4. Certificate of Compliance Rainman System Installation

A Certificate of Compliance of all Rainman equipment and installation must be provided to the City as part of the handover process. The City will NOT accept handover of any irrigation infrastructure without this Compliance Certificate.

The Certificate shall be provided by the manufacture Aquamonix once all installations have been completed in accordance's to the manufacture requirements, and the system is fully operational with no faults. For further information on this process in obtaining a Compliance Certificate, please contact Aquamonix representative.

8.5. Bore Construction Details

All details in the construction of a bore within the City of Swan will be required to be forwarded on handover acceptance by the City. These details will need to provide all the specifications in the pumps, bore's, headwork's construction, and any changes that may have been undertaken during the maintenance period by the Developer.

These changes will need to be highlighted for future reference and ongoing maintenance.

8.6. Bore Service and Logs

Prior to handover acceptance by the City of Swan, all bore's that are intended to be handed to the City, must be serviced by a registered service provider prior to handover.

All bore log details that form part of this service shall be provided to the City.

8.7. Irrigation Pump Service

Prior to handover acceptance by the City Of Swan, all irrigating pumps and all associated equipment shall be serviced and returned to the manufacture specifications prior to handover.

All service details that form part of this service shall be provided to the City.

8.8. Constructed Drawings

All "As Constructed" drawing shall be provided to the City at handover.

These drawing will need to include any changes that may have been undertaken during the maintenance period by the Developer. These changes will need to be highlighted for future reference and ongoing maintenance.

9.2. Bore Head- Junction Box

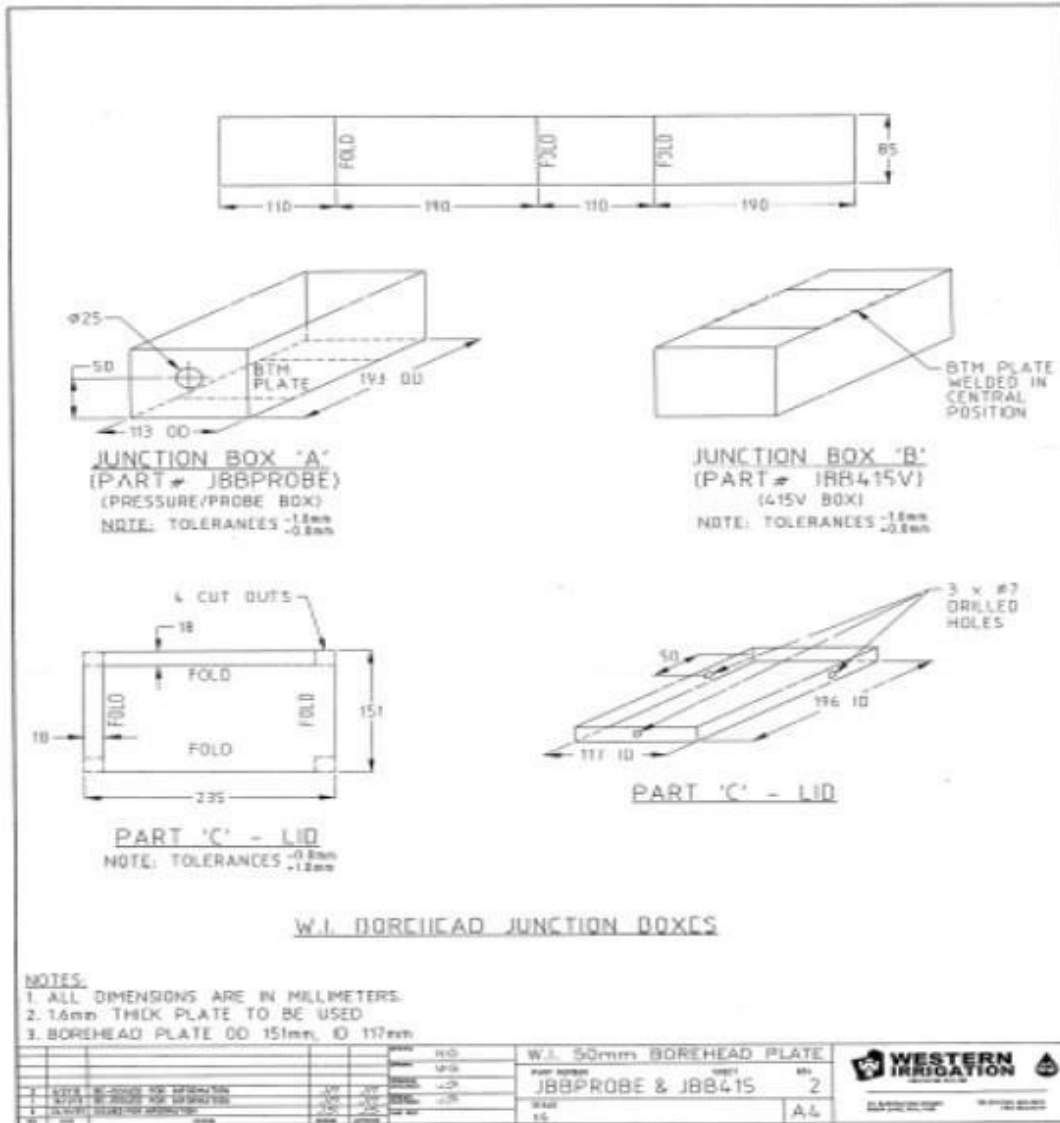

9.3. Electrical Cubicle

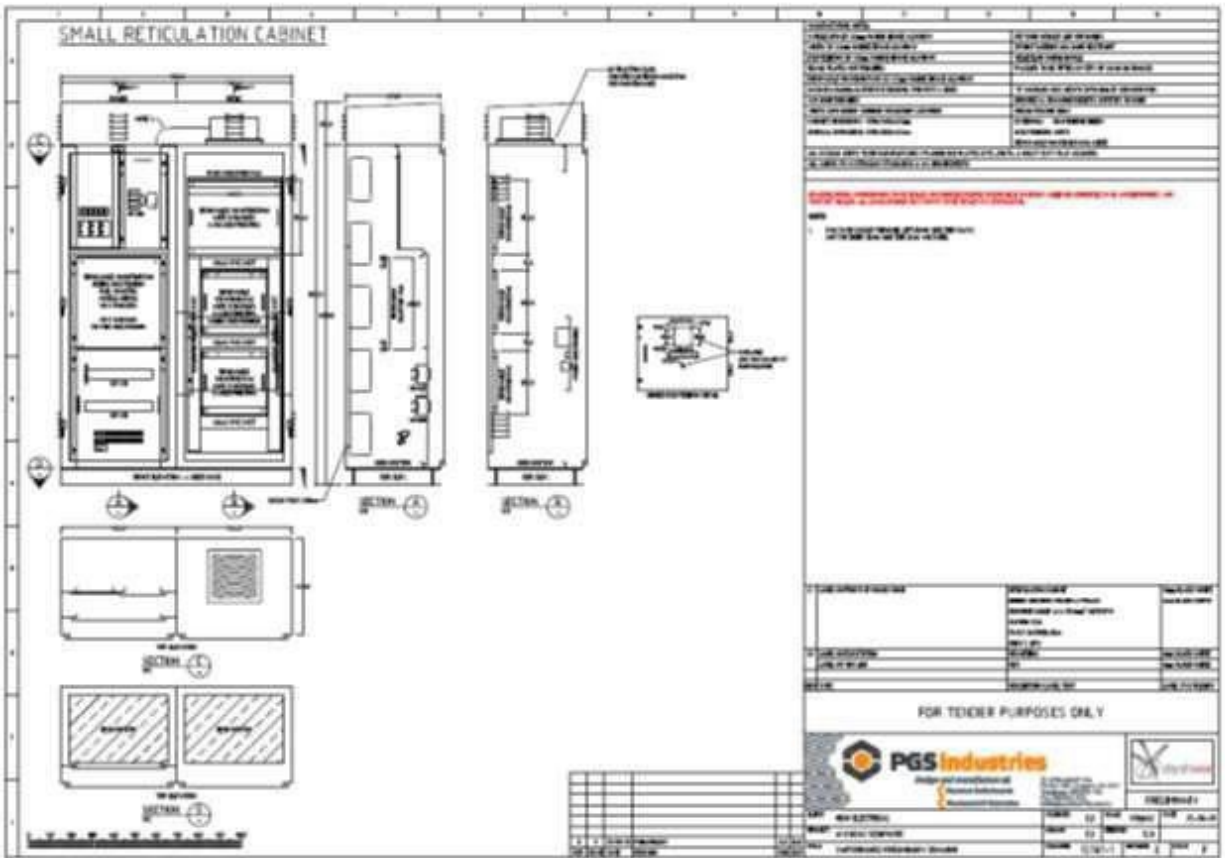

SMALL RETICULATION CABINET

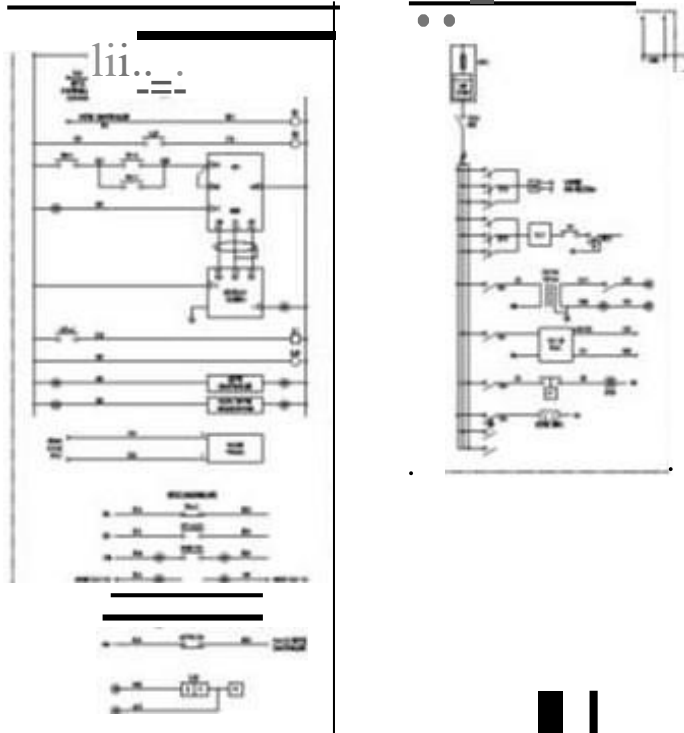

... FO CU ' -N UJ ,c , *

 PGS Industries Water & Environmental Engineering & Construction			
DATE	BY	DATE	BY
10/10/2011	J. J. J.	10/10/2011	J. J. J.
10/10/2011	J. J. J.	10/10/2011	J. J. J.
10/10/2011	J. J. J.	10/10/2011	J. J. J.

9.4. Air Release, Mainline Isolation, Flushing Valve, Solenoid Valve Assembly & Sprinkler Installation

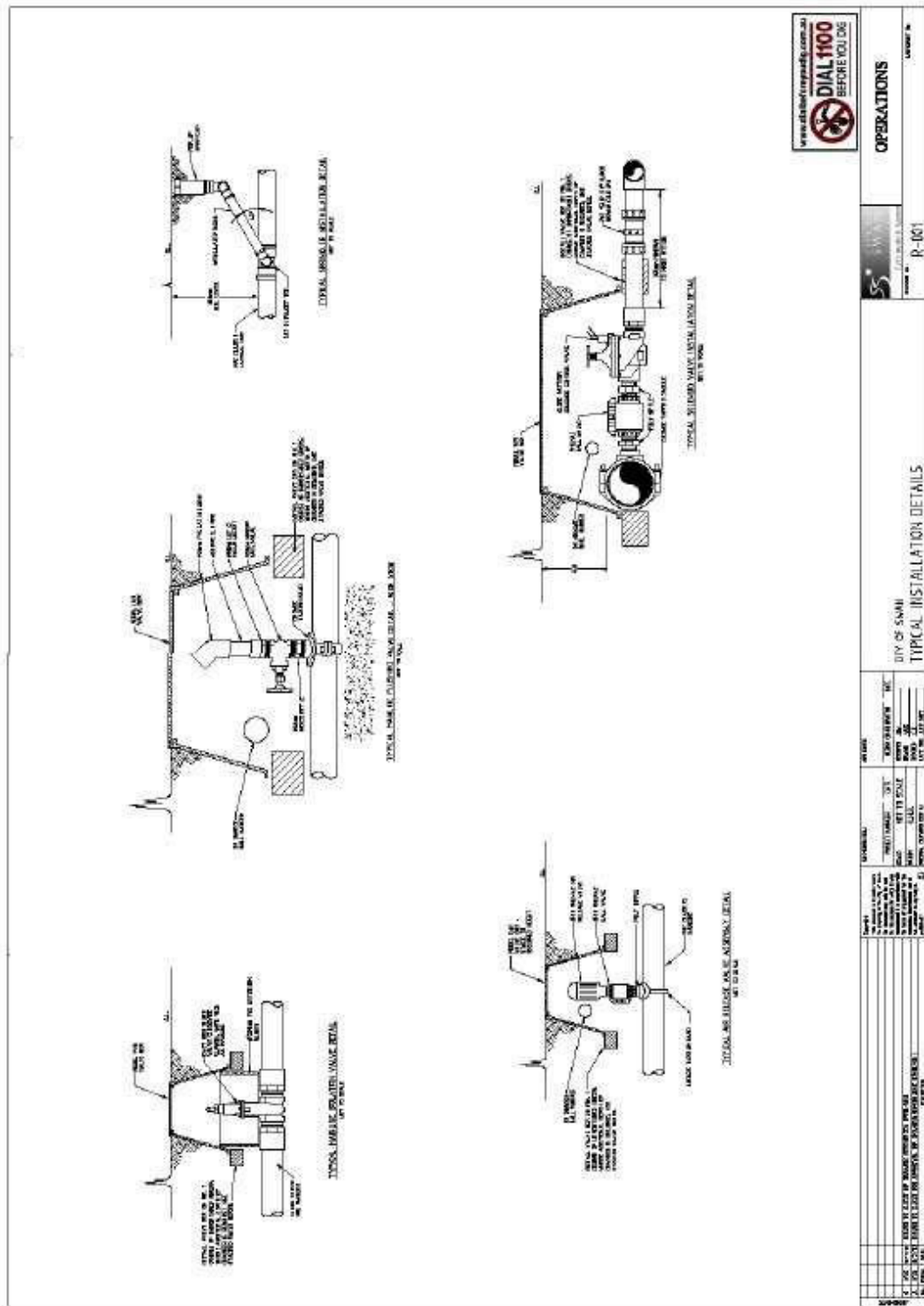

OPERATIONS



ISSUE NO. R-101

CITY OF SWAN
TYPICAL INSTALLATION DETAILS

NO.	REVISION	DATE

FOR THE CITY OF SWAN, THE ENGINEER HAS REVIEWED THESE DETAILS FOR CONFORMANCE WITH THE CITY OF SWAN STANDARD SPECIFICATIONS FOR PUBLIC WORKS, LATEST EDITION, AND THE CITY OF SWAN STANDARD SPECIFICATIONS FOR WATER SUPPLY SYSTEMS, LATEST EDITION.

9.5. Central Hub Design and Configuration

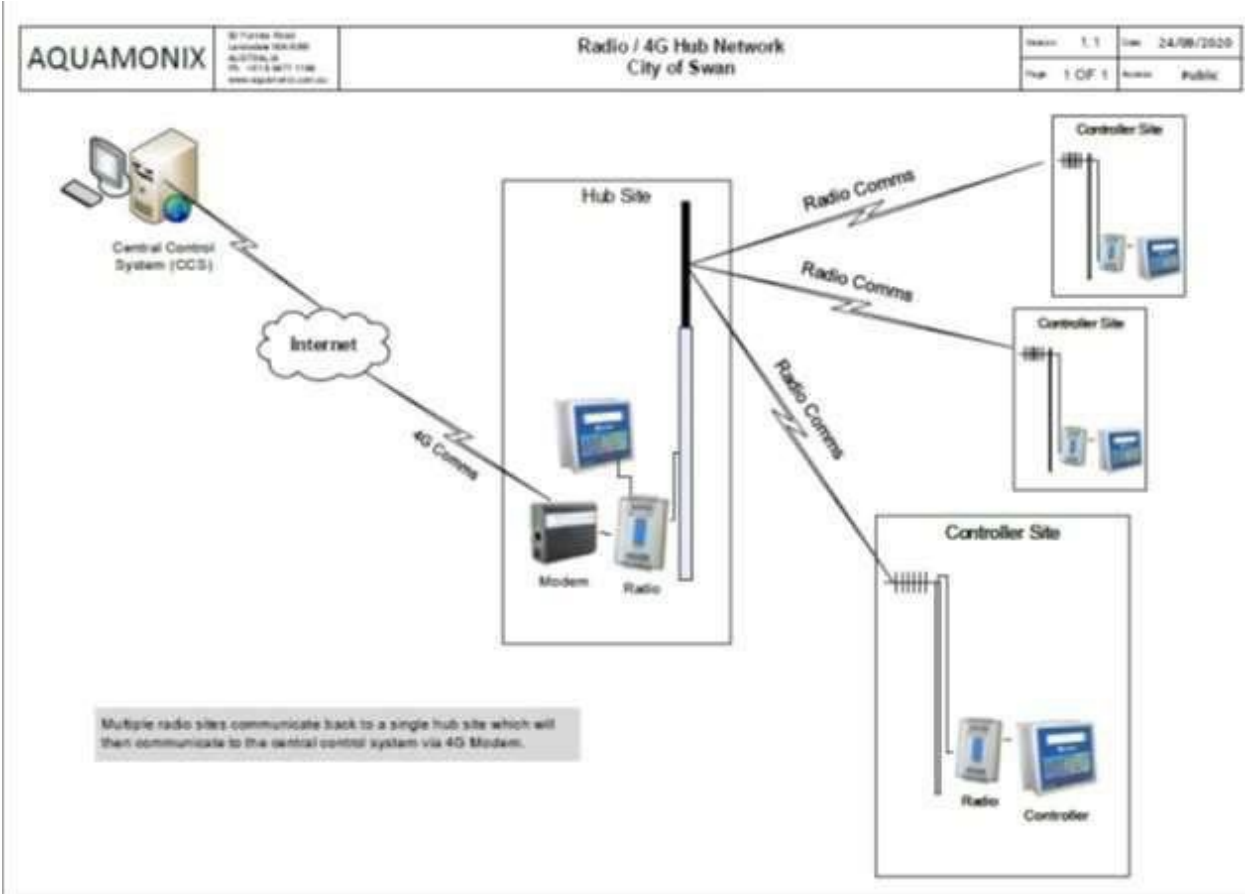

9.6. Lightning/Surge Protection

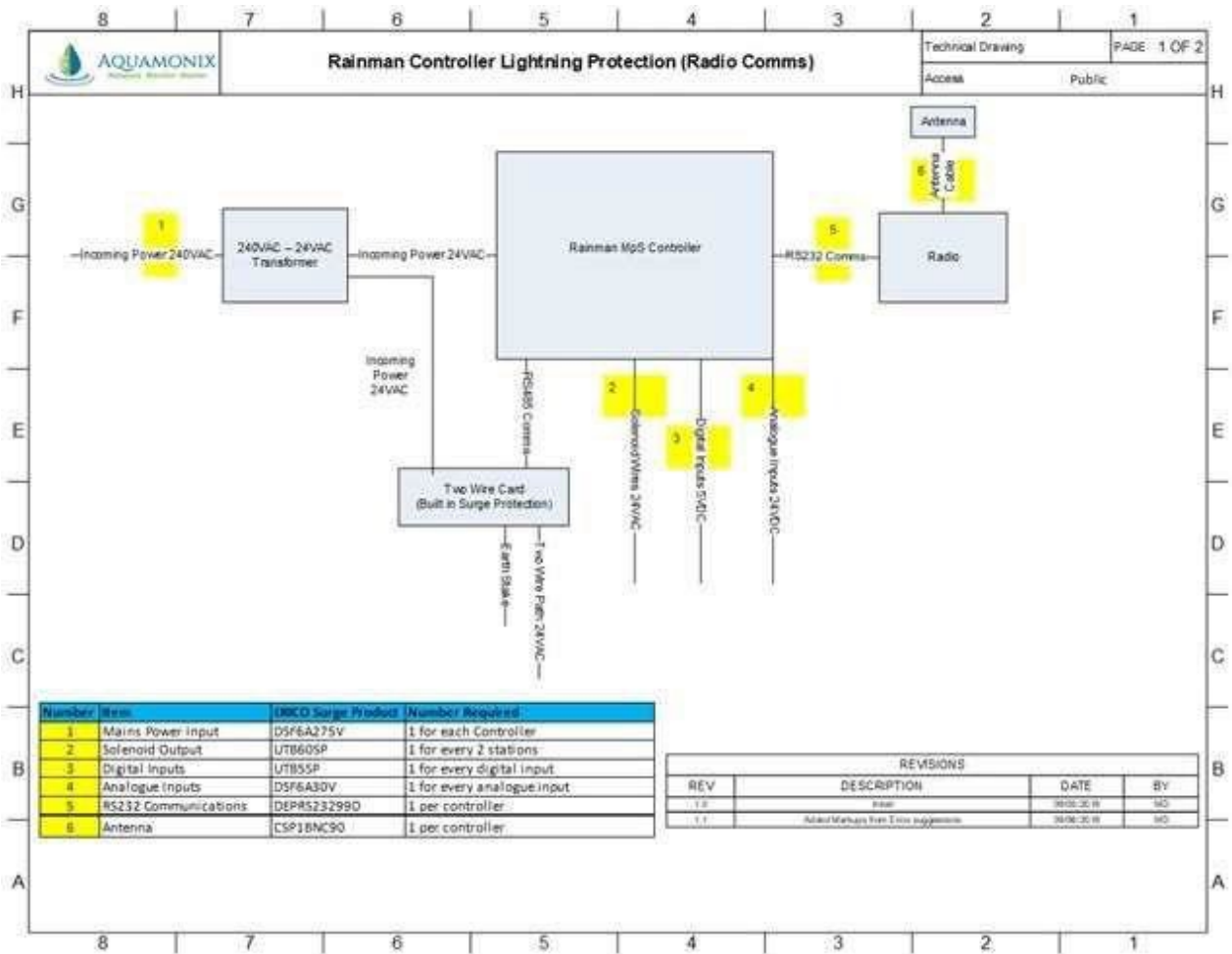

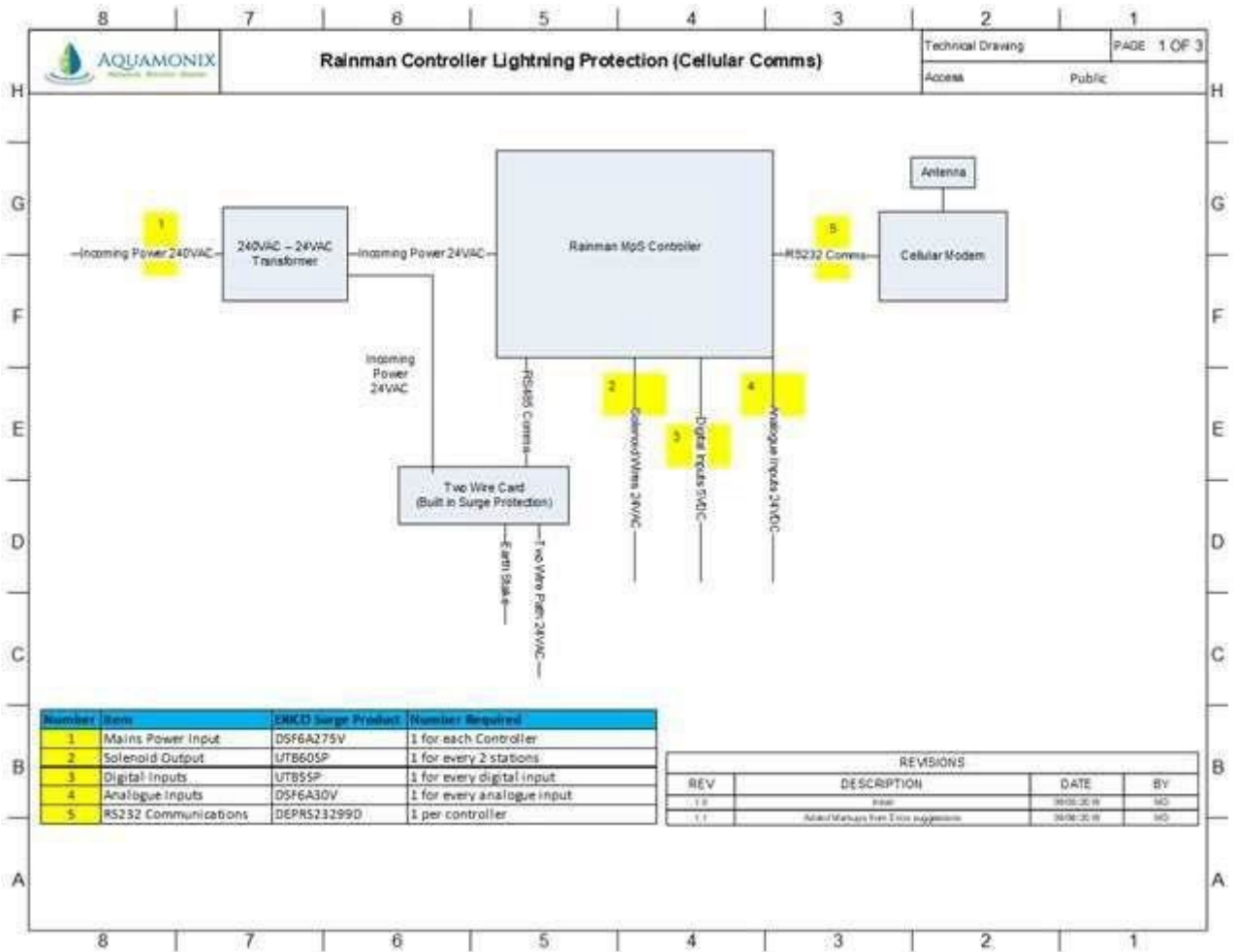

9.7. TWIN Field Cable Sizing

Maximum operating distance (metres)

Active Actuators per TWiN Decoder Translator

Cable Size	1	2	3	4	5	6
4.0mm2 Solid Core	2600	1600	1200	900	700	600
4.0mm2 Multi Core	2600	1600	1200	900	700	600
4.0mm2 Multi Core	4400	2700	2000	1500	1200	900
6.0mm2 Multi Core	6600	4100	3000	2300	1900	1600
	Max Ambient 65°C			Max Ambient 50°C		